



ACL | IYUN 2024

Jahon darajasidagi texnologiyalardan foydalangan holda sog'liqni saqlash xizmatlarini optimallashtirish

Tanishuv

Shaxsiy umidlar

Portfel (Portfolio)

Kelajak

Mukammallikka yo'naltirilgan kompaniya

ACL 1997 yilda Germaniyaning Leipzig shahrida tashkil etilgan va 1995 yilda tibbiy Monoblok PC (AiO-PC) ni ishlab chiqishda birinchi bo'lgan. Yevropaning asosiy mintaqalarida bozor ulushining 70% ni egallagan kompaniya 75 dan ortiq mamlakatlarda faoliyat yuritadi. Kompaniyaning keng qamrovli o'zida ilmiy-tadqiqot va ishlab chiqarish quvvatlari mavjud, ISO sertifikatiga ega (13485, 9001, 16949, 14001) va AQSh, Dubay va Gonkongda ofislari mavjud.



Kompaniyaning maqsadi maxsus gigiyena me'yorlarini va asbob-uskunalardan doimiy foydalanishni hisobga olgan holda, tibbiyot xodimlarini kundalik ishlari uchun eng yaxshi jihozlar bilan ta'minlash, bemorlarning xavfsizligi va farovonligini ta'minlash. Mahsulotlar osongina sozlanishi va har bir mijozning ehtiyojlariga moslashtirilgan, hatto u faqat bitta mahsulot uchun bo'lsa ham. ACL mahsulotlari uzoq umr va xavfsiz sarmoyani ta'minlaydigan 5 yilgacha kafolat bilan ta'minlanadi.

Mahsulot- larimiz ishlatiladigan joylar

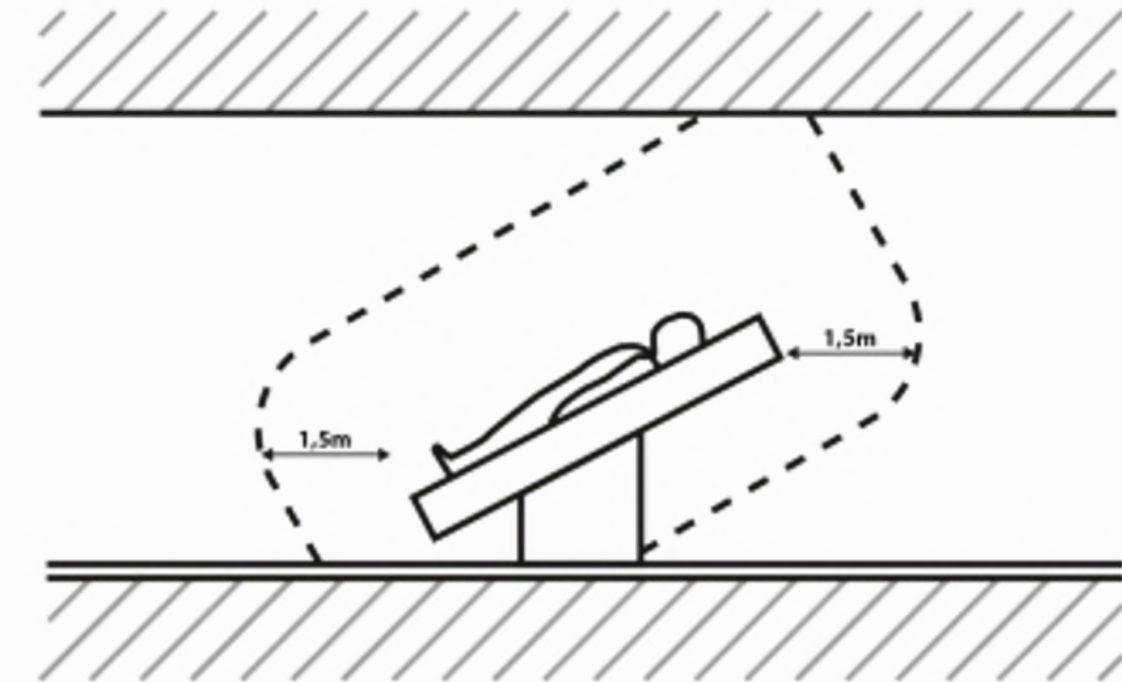
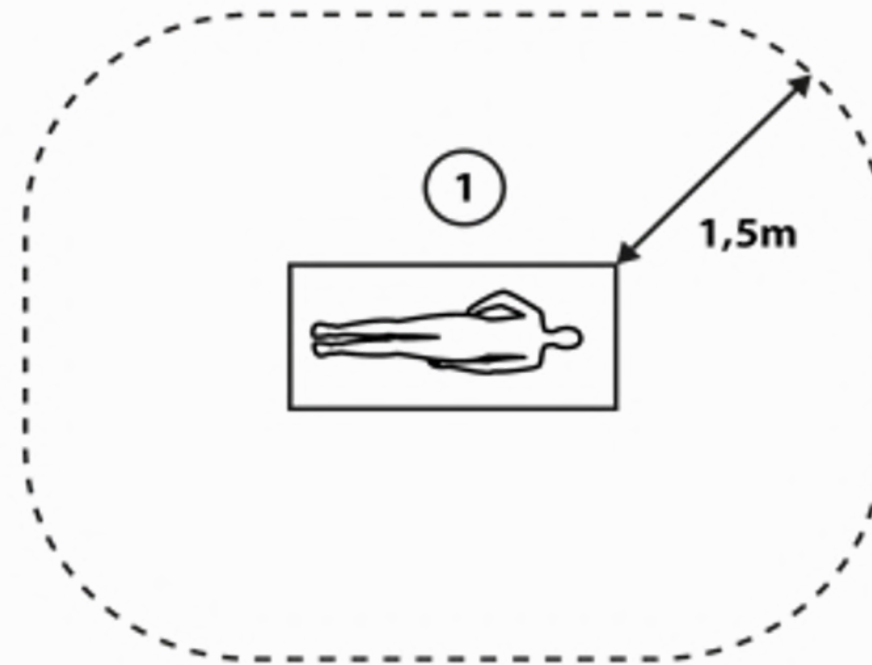

Patient environment =
equipment used either on the patient
OR in an area of approx. 1.5 m around the patient

Sinzning kelajagingiz uchun texnologiyalar



Tibbiy va gigiena muhitlari uchun IT va elektron uskunalalar

- Tibbiy kompyuterlar
- Tibbiy panelli kompyuterlar
- Tibbiy monitorlar
- Operatsiya xonalari uchun katta formatli tibbiy ekranlar
- Mobil tibbiy kompyuterlar
- Tibbiyotda foydalanish uchun moslashtirilgan qurilmalarni ishlab chiqish



Sizning kontaktingiz



Gregor Kern

- Global savdo direktori, ACL GmbH
- Tibbiy IT sohasida xalqaro biznesni rivojlantirish va bozorga kirishda 24 yillik tajriba
- angi innovatsion mahsulotlarni ishlab chiqish va bozorga chiqarish bo'yicha ko'p yillik tajriba
- Tibbiyot texnologiyalari sohasida keng xalqaro tarmoq
- LinkedIn: <https://www.linkedin.com/in/gregor-kern-75b02259/>

Sizning kontaktingiz



- IT menejer, ACL GmbH
- ACLda 8 yil, IT infratuzilmasi uchun mas'ul.
- LinkedIn: <https://de.linkedin.com/in/erkin-ismoilov>

Erkinbek Ismoilov

Shaxsiy umidlar



Nima uchun O'zbekiston?

- Global biznesni kengaytirish uchun korporativ strategiya
- Barqaror munosabatlarni yaratish
- O'zbekiston o'sib borayotgan bozor va biz sog'liqni saqlash xizmatlarini doimiy ravishda kengaytirishni qo'llab-quvvatlamogchimiz
- Bizning tajribamiz va nou-xau foydali bo'lishiga ishonamiz.
- Moslashuvchanligimiz tufayli biz qozog'istonlik mijozlarning shaxsiy ehtiyojlariga optimal tarzda javob bera olishimizga aminmiz
- Biz O'zbekiston bozori va bu bozordagi qiyinchiliklar haqida bilmoqchimiz
- O'zbekistonlik hamkorlar bilan birgalikda yangi yechimlarni ishlab chiqish.

Qo'llab- quvvatlash

Tajribasi ishonch...

- Boshqa bozorlarda qilingan "xatolar" dan qanday qochish kerak
- Yangi texnologiyalar bo'yicha maslahat berish odatda yangi jarayonlar va ish jarayonlarini talab qiladi
- Eng yaxshi natijalarga erishish, xodimlarning yuqori qoniqishi va bemorning maksimal farovonligi va xavfsizligiga erishish uchun optimal texnik echimlarni olish va **ulardan foydalanishni** qo'llab-quvvatlash.
- Investitsiyalarni himoya qilish "Sifatga nisbatan narx".

Portfel (Portfolio)



Dräger

Movita

OCL

Dräger

Movita

10









OR-PC®
our centrepiece for strenuous
non-stop operation



OR-MD®
the best image
in FHD and 4K



OR-CONSOLE®
the individual and versatile wall
module



Mobile solution
perfectly assembled ward
trolley



OR-PC® Hot Swap Battery
mobile use in continuous
operation



OR-PAD® Medical Tablet
the reliable companion
in daily hospital work



OR-PC® Box / Box Mini
compactness with full
computing power

OR-PC®



OR-MD[®] Medical Display



OR-PC[®] Hot Swap



OR-PAD®



OR-PC[®] BOX

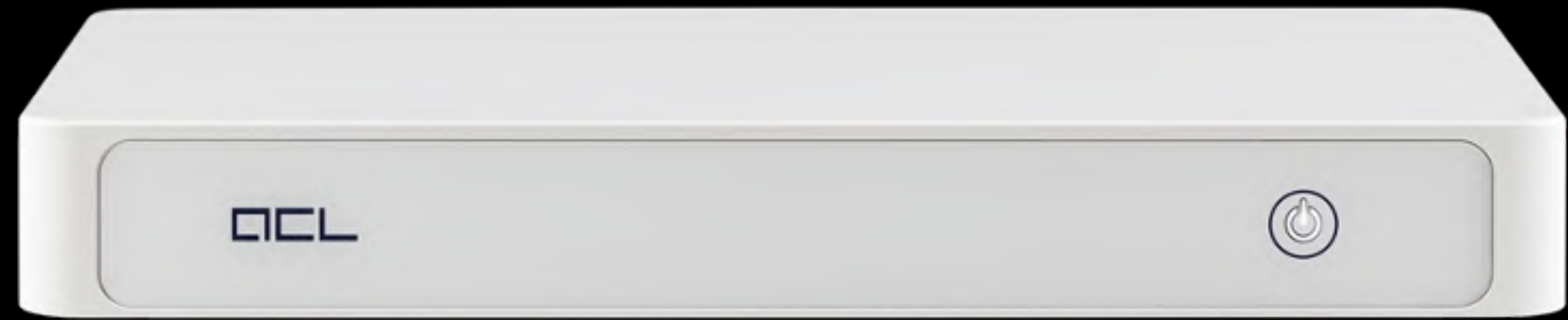

OR-Console®

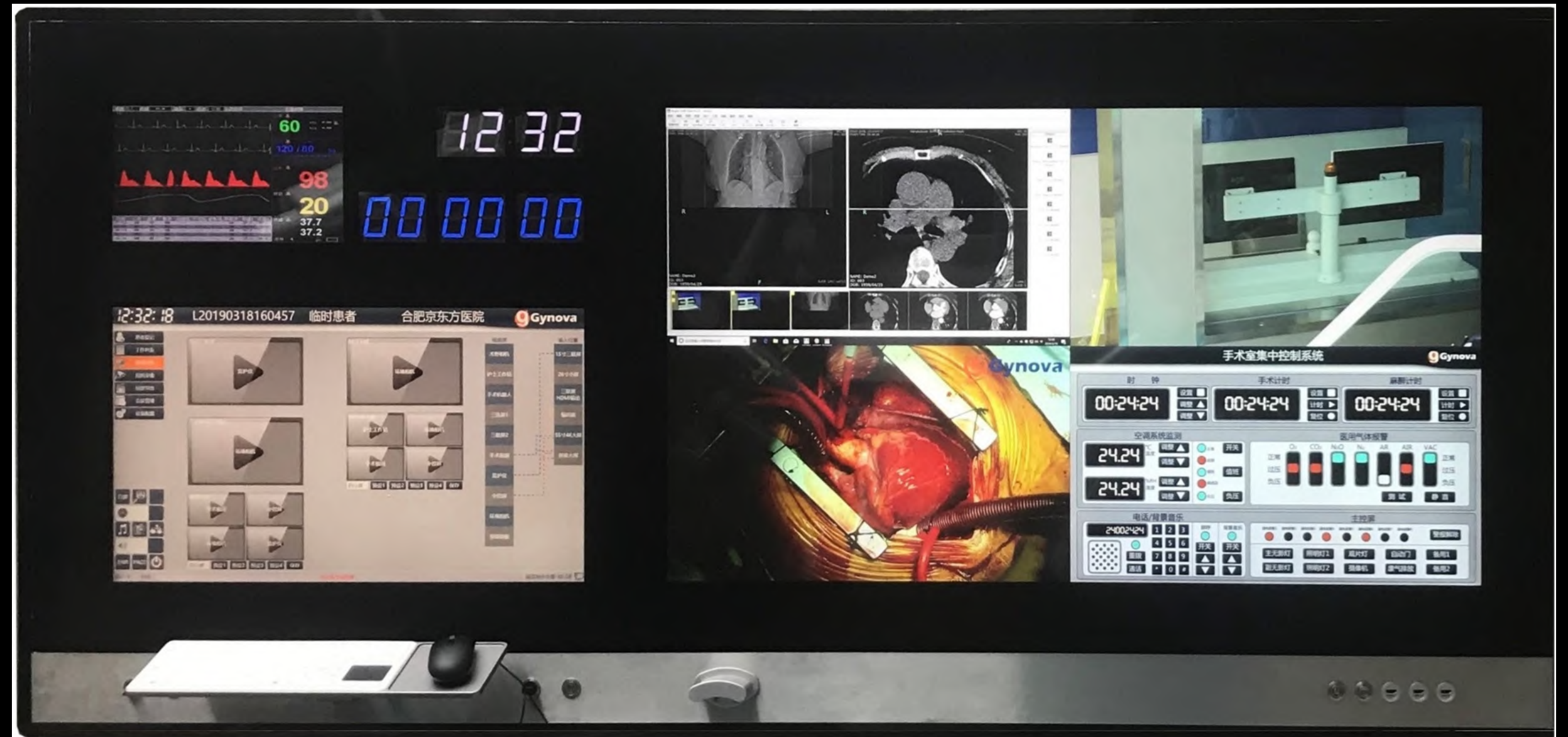

OR-CART®



Rivojlanish | Kelajak



ACL[®] Oasis



Oasis Pod



Oasis Corner

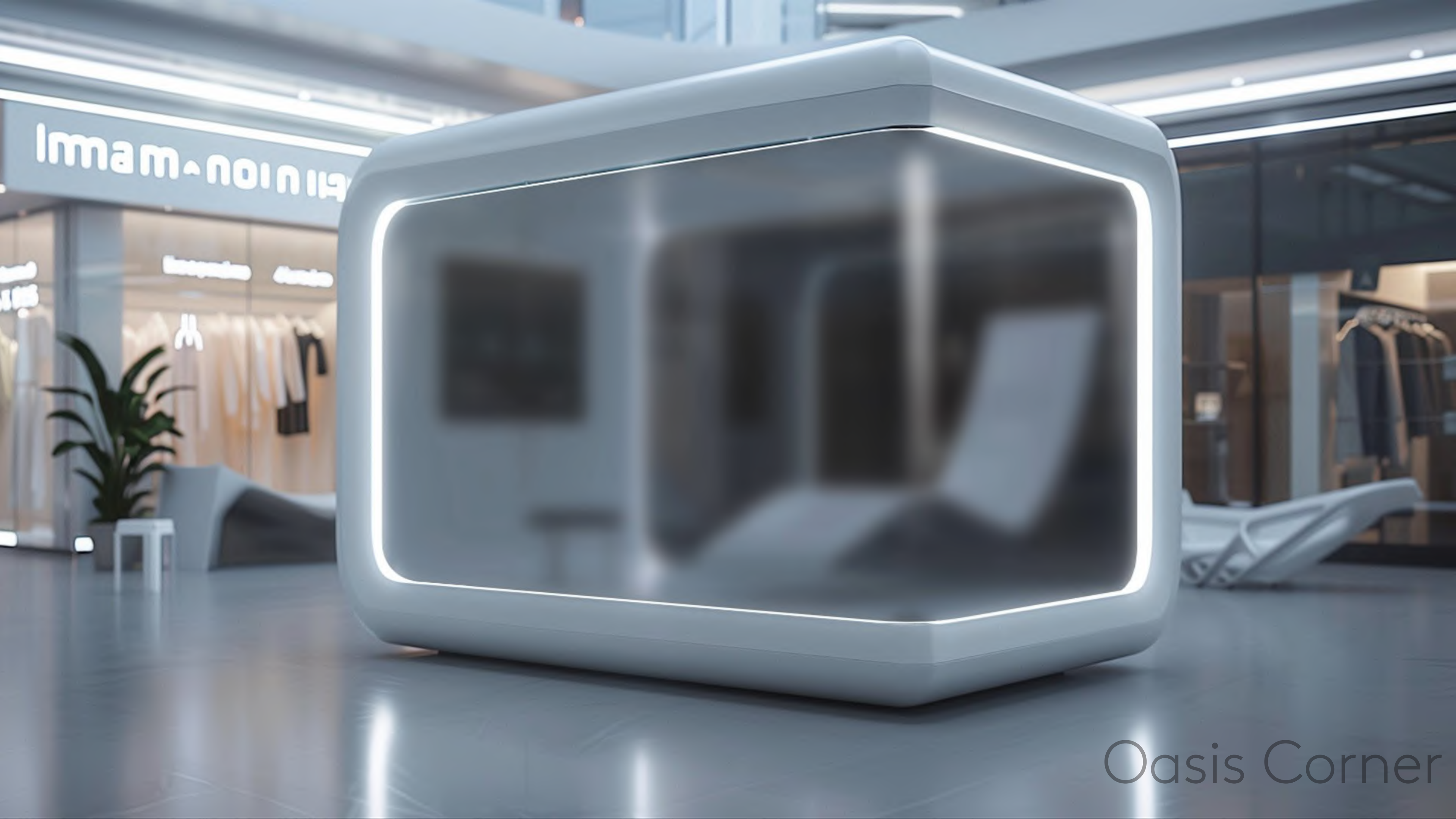

Imam

Oasis Corner

Kontseptual tadqiqotlar





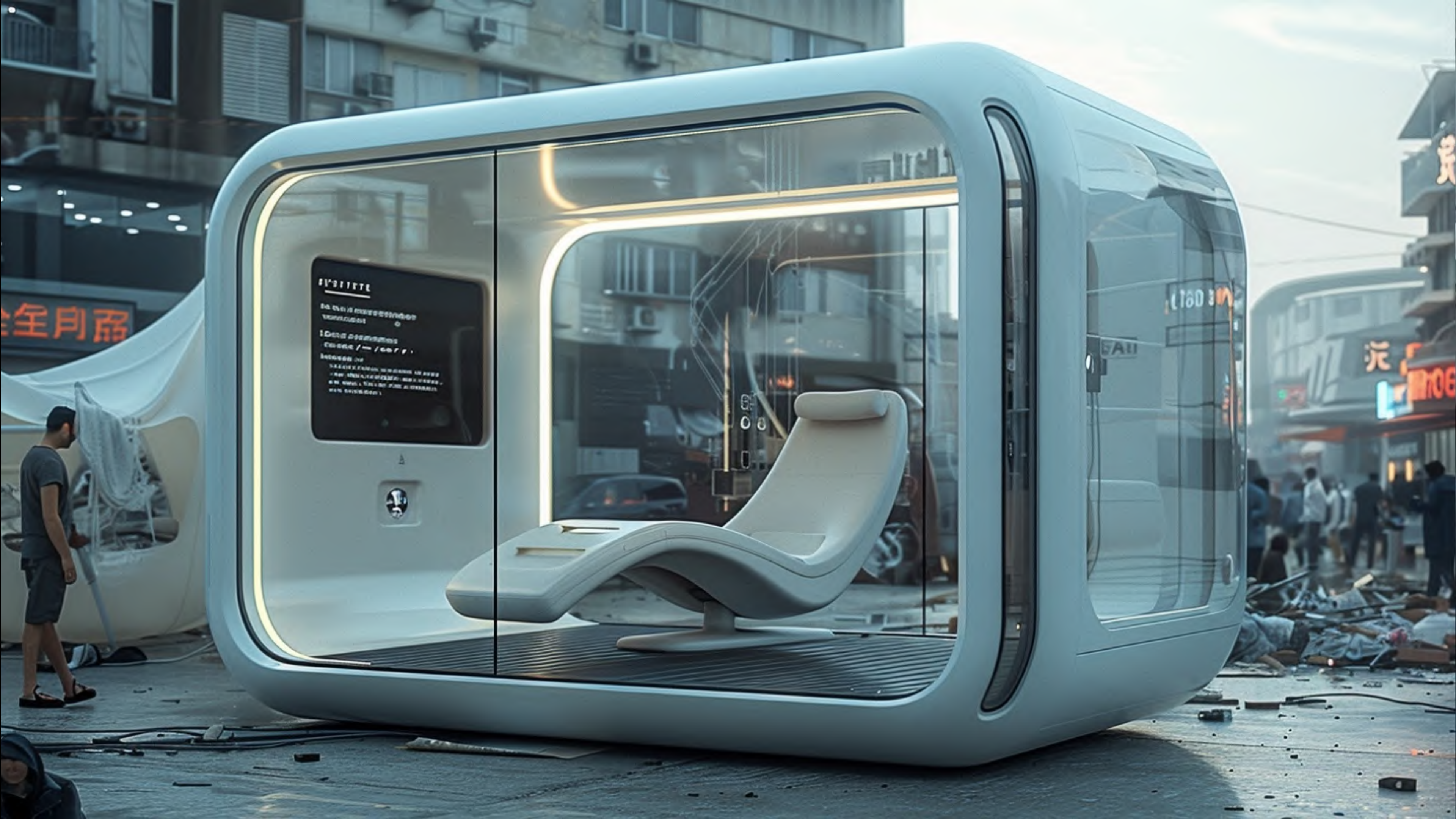

ИЗМЕНЕ
ПО ДИСТАНЦИОННОМУ
УПРАВЛЕНИЮ
1. ДАННЫЕ ОБ АВТОМАТЕ
СЕРИЯ / № / ГОД П.
2. КОДЕС НА
3. НАЗНАЧЕНИЕ АВТОМАТА
4. ПОДРОБНОСТИ ОБ АВТОМАТЕ
5. ВНЕШНИЙ ВИД АВТОМАТА
6. ДАННЫЕ ОБ АВТОМАТЕ

全月器

160

元



ΒΡΑΙΟ ΟΥ
ΒΙΟΥΤΗΛΙΝΙΤΣ
ΕΛΛΗΝΙΚΗ
ΕΠΙΧΕΙΡΗΣΗ
1991

BV
T
ΕΛΛΗΝΙΚΗ
ΕΠΙΧΕΙΡΗΣΗ



Biz birgalikda nima qila olamiz?

Gregor Kern

Global savdo direktori

Mobil : +49 160 9397 10 00

Email: g.kern@acl.de

LinkedIn: GregorKern

Biz ijtimoiy tarmoqlarda:

www.facebook.com/acl.gmbh

www.linkedin.com/company/acl-gmbh

DEL

Always a Step Ahead



MADE IN GERMANY